

POS X

POINT OF SALE
SIMPLIFIED

EVO Laser

Barcode Scanner

Get high performance and increased reliability for a fraction of the cost with the new POS-X EVO Laser Scanner. The EVO Laser increases accuracy thanks to a wide scan area with a longer depth of field and proves more reliable due to decreased working time for the laser head. In addition, the advanced ergonomic design contributes to the EVO Laser's standing as a highly efficient, cost effective rapid-fire scanner.



Key Features

- World-leading laser technology
- Pulsing laser increases the life of the laser engine
- Reads all linear barcodes
- Reads barcodes in direct sunlight
- Reading distance: 0.5"–10"
- 5-Year warranty includes 2-Day Advance Exchange service

barcode scanner

EVO Laser Specifications

PART NUMBER	EVO-SG1-ALU
PERFORMANCE	
Light Source	Visible Laser Diode 650nm
Visual Indicators	Green = laser ready to scan; Red = scanning successful
System Interface	USB
Depth of Field	0.5" (12.7mm)–10" (257mm) .01" (.33mm) barcode
Resolution	0.2" (4 mm)
Scanning Angle	46 degrees horizontal
Scan Rate	72 ± 2 scan lines/sec
Print Contrast	Minimum 35% contrast
Ambient Light Rejection	0–4842 LUX
FEATURES	
Supported Symbologies	1D: Code 128, Code 39, Extended Code 39, Code 93, EAN 13, EAN 8, EAN Bookland, Industrial 2 of 5, Interleaved 2 of 5, Logmars, OPC, SCC-14, UCC/EAN Shipping, UPC Shipping Container Code, UPC-A, UPC-E
Programmable Features	Scan mode, prefix code, postfix code, code type, Supplements, Redundant scans, Transmission delay
PHYSICAL	
Weight	0.26 lb (117 g)
Housing	ABS
Dimensions	(LxWxH) 6.5" (165mm)x 2.8" (70mm)x 3.7" (95 mm)
Color	Black/Grey
ELECTRICAL	5V DC ± 0.25 V (input)
CURRENT	125mA
ENVIRONMENTAL	
Temperature	32°–104°F (0°C to 40°C) (operating) -40°–140°F (-40°C to 60°C) (storage)
Humidity	5%–95% relative humidity, non-condensing
Shock Resistance	Withstands multiple drops from 3.3' (1 m)
WARRANTY	5-Year Includes 2-Day Advance Replacement Service
CERTIFICATIONS	SELV, CSA, CDRH

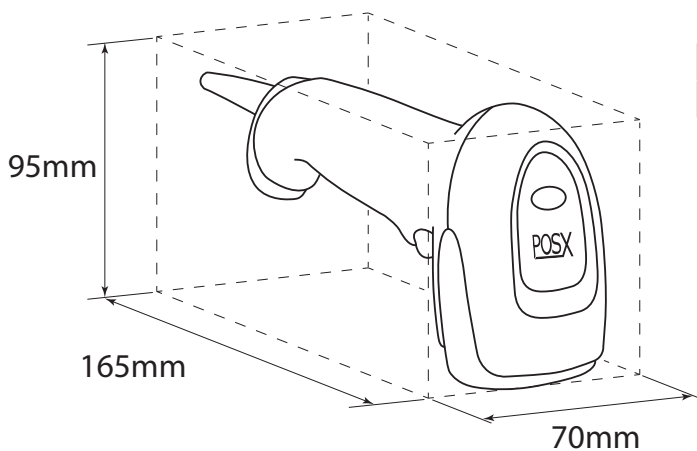

ACCESSORIES	
EVO-SG1-ASTAND	EVO Scanner Stand

Legacy Technology Services

We Rent & Sell All Types Of Barcode Equipment

Call now to talk to an expert

866-271-9891

www.LegacyGlobal.com

Some brands we carry



MOTOROLA

Intermec

DATALOGIC™

Honeywell

EQUINOX
PAYMENTS



About us

- Legacy Technology Services is a leading nationwide provider of mobile computing, barcode, printers and point of sale equipment and services.
- For over a decade, thousands of clients across North America have trusted us to provide equipment from leading manufacturers backed by the services to support them.

Latest Hardware from top manufacturers

- Legacy handles virtually every major manufacturer of mobile computing, barcoding and point of sale equipment.

Expert Repair and Maintenance services

- Legacy is one of the best repair facilities in North America

Discontinued product sourcing

- They don't make it anymore? Our inventory also includes manufacturer close-outs and discontinued equipment to support our clients legacy infrastructure.

Trade-in and Disposal services

- That old equipment laying around your facility may still have some value. Legacy routinely purchases equipment from our clients around the globe.
 - Data destruction
 - Hardware disposal
 - Auditing services

Dedicated client account team

- Dedicated, highly trained account managers are here to answer all your questions and provide top notch service.

Equipment rental services

- Sometimes renting is a better solution, Legacy's huge rental inventory provides the equipment you need for temporary needs and projects.



Legacy, Inc.

160 West Road,
Ellington, CT 06029

Toll Free: 866-271-9891

Fax: 888-522-4684